

Sailing Instructions

One Design Summer Series

Hosted by Sandpoint Sailing Association & J24 Fleet 174
Windbag Marina – May - September 2022

1. RULES

- 1.1 This series will be governed by the rules as defined in the 2021-2024 Racing Rules of Sailing (RRS) and appropriate OD Rules (J24 and Capri 25).
- 1.2 Changes to the rules may be noted elsewhere in the NOR or SIs.

2. NOTICES TO COMPETITORS

- 2.1 The Race Committee (RC) may provide unofficial communication, which is communication not governed by the rules, at any time by hail or over VHF channel 72. A request for redress may not be based on any aspect of unofficial communication, including content, timeliness, or failure to hear. This changes RRS 62.1(a).
- 2.2 The preferred VHF radio channel will be 72.
- 2.3 Notices to competitors will be posted on sandpointsailing.org.

3. SIGNALS MADE ASHORE

- 3.1 Signals made ashore will be made on the RC boat flagpoles when the committee boat is docked. The RC will attempt courtesy broadcasts on VHF radio channel 72.
- 3.2 In the event of an on-shore postponement, no starting signal will be made earlier than thirty (30) minutes following the lowering of the signal flag. This changes RRS "Race Signals – AP and AP over H".

4. RACE COMMITTEE

- 4.1 The RC boat shall be the SSA pontoon boat or a designated alternative. The RC boat shall be the boat displaying the orange start/finish flag (at start).

5. RACING AREA

- 5.1 Windward/leeward courses shall be bounded by the RR Bridge to the south, Kootenai Point to the north, and Contest Point to the South East, unless notified by the Race Committee. This is the area to the west of the red line (figure 1).

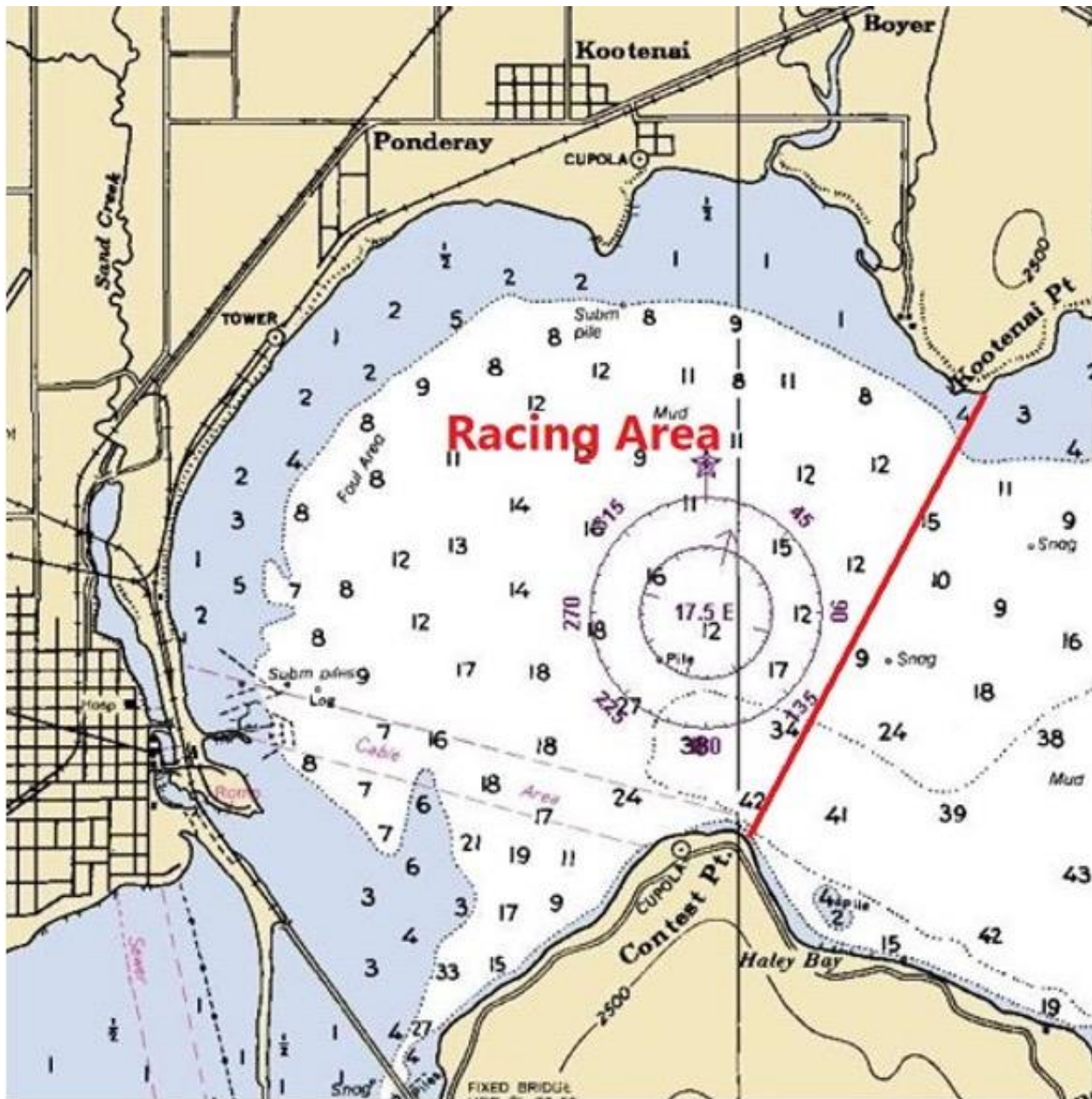

Figure 1

6. COURSES

- 6.1 Courses will be Windward - Leeward.
- 6.2 Windward – Leeward courses will be two laps, unless the Race Committee flies the shortened course flag, in which case the distance will be one lap.
 - 6.1.1 Windward - Leeward **Course A** shall be a mid course start line; all mark roundings shall be taken to port. The course shall be sailed Start, Windward, Leeward, Windward, Leeward, Finish.

6.1.2 Windward - Leeward **Course B** shall include a leeward gate. The leeward mark and committee boat establish the start and finish line as well as the leeward gate. This course has a downwind finish. The course shall be sailed Start, Windward, Leeward Gate, Windward, Finish.

Course A

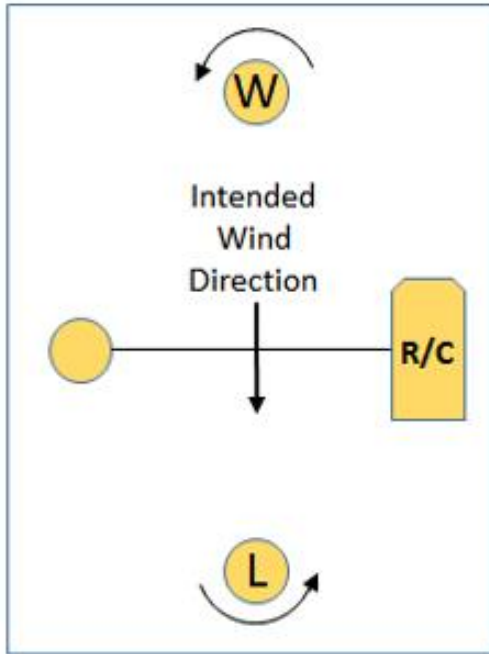

Course B

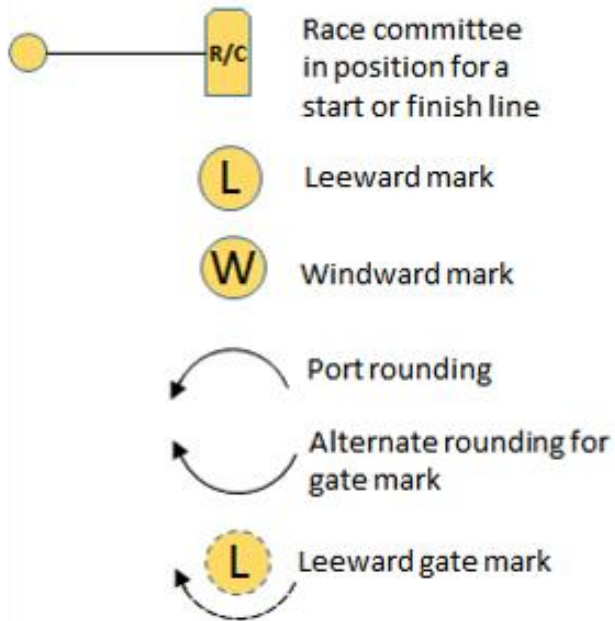
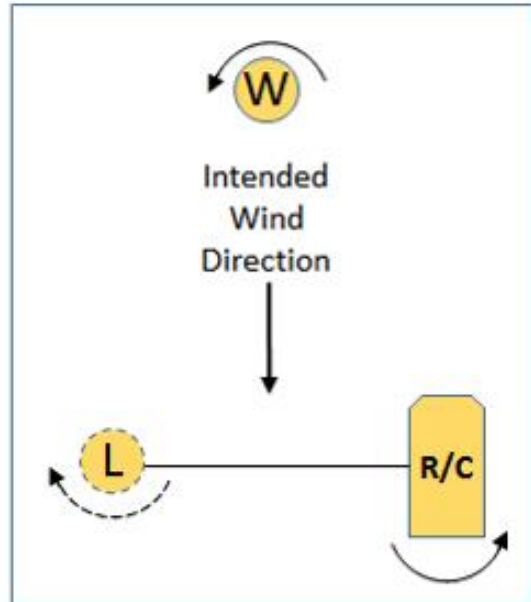

- 6.4 If a continuing (in excess of 5 minutes) wind shift of 30 degrees or more occurs after the start of a fleet, but before the first boat passes the first windward mark, the race shall be abandoned and restarted. The course shall be reset and the Race Committee shall restart. If such a shift occurs after the first boat in the fleet has rounded the windward mark, a shortened course will be called, the mark shall be reset after all boats in that Fleet have rounded the leeward mark. Determination of time and amount of shift is in the sole judgment of RC and it is not subject to protest, appeal or hearing.

7. THE START

- 7.1 The starting line shall be between a staff displaying an orange flag on the race committee signal boat and the course side of the starting mark buoy.
- 7.2 All boats that assume to race on the set racecourse must sail behind the committee boat with the mainsail up to check-in. Race committee will hail sail numbers as checked-in.
- 7.3 A boat starting later than 10 minutes after her starting signal will be scored Did Not Start (DNS) without a hearing. This changes rule A5.2.
- 7.4 If a boat is subject to RRS 29.1, Individual Recall the race committee may attempt to hail her sail number through channel 72 on VHF radio. This is an unofficial communication as in Sailing Instructions 2.2.

8. THE FINISH

- 8.1 The finishing line will be between a staff displaying an orange flag on the race committee signal boat and the course side finishing mark.
- 8.2 The race committee may adjust the finishing marks to maintain the finishing line without regard to RRS 33.

9. TIME LIMIT

- 9.1 If no boat sails the course and finishes within 90 minutes after her start, the race will be abandoned. Boats failing to finish within 30 minutes after the first boat sails the course and finishes, will be scored Did Not Finish (DNF) without a hearing. This changes RRS 35, A4 and A5.

10. PROTESTS AND PENALTIES

- 10.1 A boat intending to protest or request redress for an incident that occurred while racing must orally notify the race committee on the signal boat as soon as reasonably possible after retiring or finishing by hail or VHF until she receives oral confirmation from the race committee.
- 10.2 Fleet Captains shall be informed by the race committee of a protest or request for redress hearing as soon as practical. The Fleet Captains will assemble a Protest Committee, which will be composed of three representatives from boats not involved in the incident.
- 10.3 Protest forms are available at the Windbag Marina. Protests or requests for redress must be delivered to either the J24 or Capri 25 Fleet Captain within 15 minutes of RC docking.
- 10.4 All hearings will be at Fred's Deck unless inclement weather forces a hearing at an alternate location.
- 10.4 A boat may take a One-Turn Penalty when she may have broken one or more rules of Part 2 or rule 31 in an incident while racing unless the incident occurred within the zone in which case a boat may take a Two-Turn Penalty. This changes RRS rule 44.1.

11. SCORING

- 11.1 Boats will be scored in class.
- 11.2 RRS rule A5.3 applies.
- 11.3 A minimum of 4 races will constitute Summer Series 1 and a minimum of 4 races will constitute Summer Series 2. The overall summer fleet champions will be a combination of all races sailed in Summer Series 1 and Summer Series 2
- 11.4 A boat's Summer Series 1, Summer Series 2, and Overall Fleet Champion (combined Summer 1 and Summer 2) score shall be the total of her scores excluding her worst score if at least four races are completed, two worst scores excluded if at least seven races are completed and three worst scores if at least 10 races are completed.

12. RADIO COMMUNICATIONS

- 12.1 Except in an emergency, a boat shall neither make radio transmissions while racing, nor receive radio communications not available to all boats. This restriction also applies to mobile telephones.

13. REPLACEMENT OF CREW OR EQUIPMENT

- 13.1 Crew may be substituted without approval of the Race Committee.

14. EQUIPMENT AND MEASUREMENT CHECKS

- 14.1 On the water, a boat can be instructed by a member of the race committee to proceed immediately to a designated area for inspection. Ashore, equipment may be inspected or measured at times specified in the class rules or the notice of race.

15. SAFETY

- 15.1 A boat that retires (RET) from a race shall notify the race committee as soon as possible.
- 15.2 Competitors participate in racing entirely at their own risk. See RRS 4, Decision to Race.
- 15.3 The organizing authority will not accept any liability for material damage or personal injury or death sustained prior to, in conjunction with, or after racing.